

LOCKABLE SELF CLOSING GATE



SCOPE OF OPERATION

- This gate has been design to meet the needs of a Manual closing swing gate and the barrier of a manual locking gate, all in one.
- The Lockable self closing gate can be used as a closure gate for blocking the passage of pedestrian traffic or can be used to control how customers enter and exit your premises.
- Unit comes equipped with an emergency breakaway feature that allows them to meet any building or fire code regulations.

MATERIALS

All materials meet the ASTM standards as set forth by the materials industry.

- the gate post is constructed out of 14 gauge tube
- Mechanical breakaway are made with all heat treated component parts
- Lock mechanism assembly for closure locking
- Arm closing: controlled by shock absorber for soft opening and closing.
- Adjustable top cap assembly for speed closing control
- Standard gate arm lengths for ADA compliance
- Complete with white ABS sign panel and channels
- Custom length arms can be fabricated.
- Anchor bolts are hidden by a cover which snaps over the floor mounting plate.

FEATURES

- Allows for left hand or right hand operation. The direction is set during fabrication
- Panic breakaway provides an exit path in case of emergency
- One way passage only
- Adjustable hydraulic speed control.
- Tumbler style key lock, provides ability to lock gate in home position

OPTIONS

- Universal and custom signage
- Custom gate arm lengths can be fabricated.

FINISHES

- Bright Chrome
- Satin Chrome Finish
- Powder Coat Paint.

ELEVATION DIAGRAM & LOCKING MECHANISM

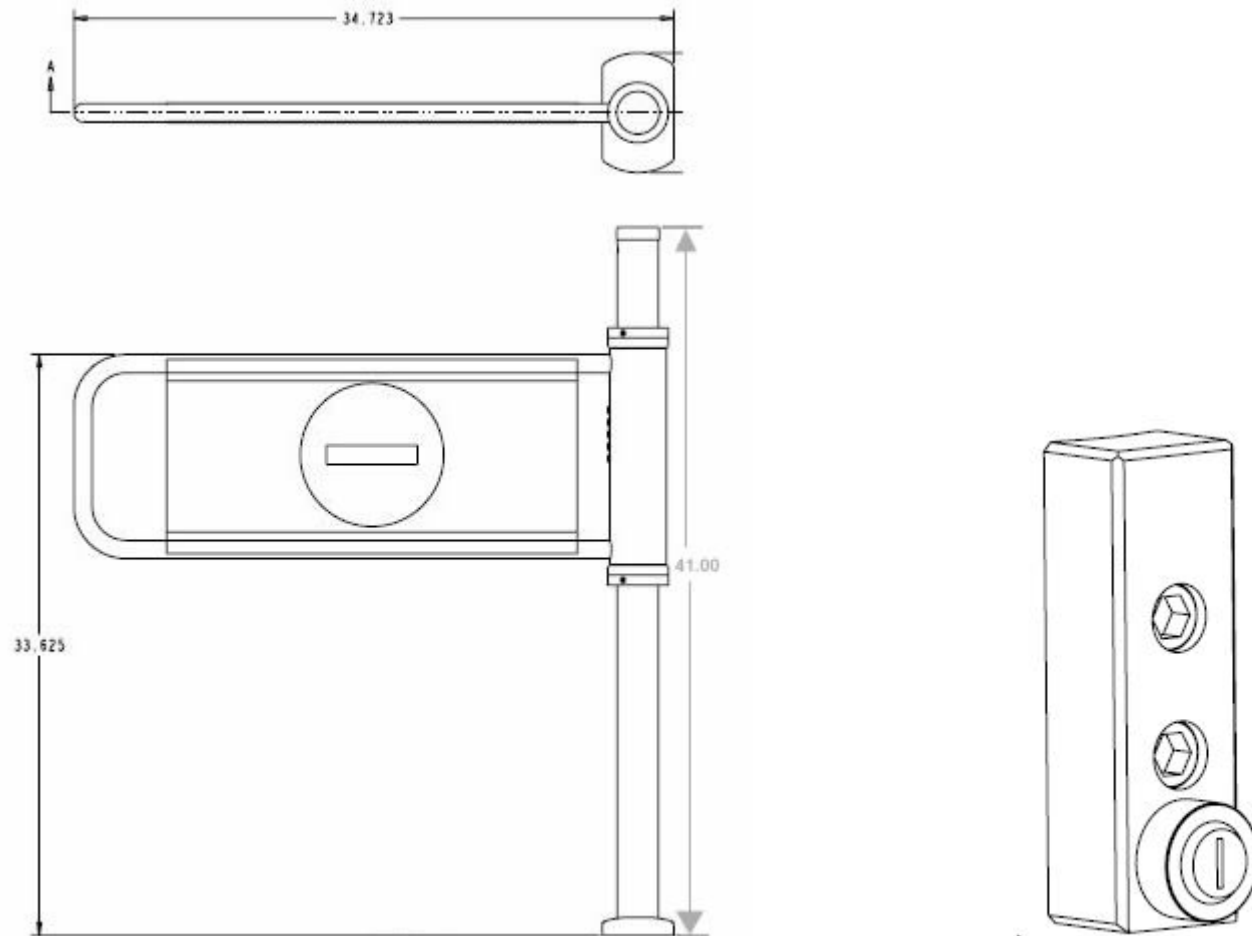

FLOOR PLAN

